



flanges australia

Forged Steel BALL VALVES



Forged Steel BALL VALVES SKH

Series 050

DN 4 TO DN 50

Body, connecting parts, ball and stem steel.

Fields of application:

hydraulics, water engineering, paint industries, steam, thermo oil

Body: C22.8/ST52-3 (ab DN32)
 Ball: Steel nickel pl.
 Stem: Steel zinc pl.
 Ball sealing: Polyamid/POM (ab DN 32)
 Stem sealing: NBR

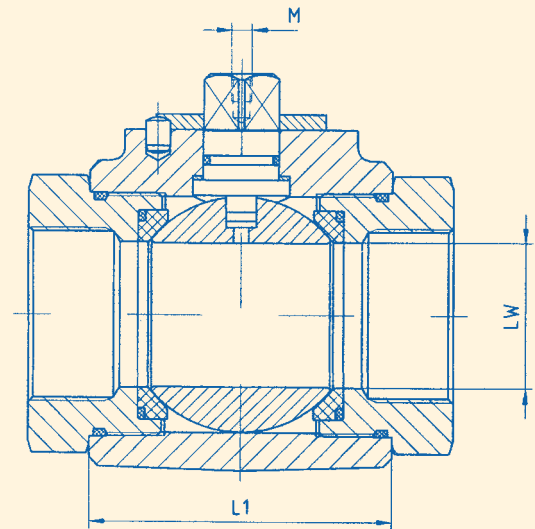

Connection	DN mm	LW mm	D	PN BAR	Part Number
BSP female thread DIN/ISO 228	4	5	G $\frac{1}{8}$	600	SKHG 18
	6	6	G $\frac{1}{4}$	600	SKHG 14
	8	8	G $\frac{3}{8}$	600	SKHG 38/8
	10	10	G $\frac{3}{8}$	500	SKHG 38
	13	13	G $\frac{1}{2}$	500	SKHG 12
	20	20	G $\frac{3}{4}$	420	SKHG 34
	25	24	G1	420	SKHG 1
	32	24	G1 $\frac{1}{4}$	420	SKHG 114/24
	40	24	G1 $\frac{1}{2}$	420	SKHG 112/24
	*32	32	G1 $\frac{1}{4}$	420	SKHG 114
	40	32	G1 $\frac{1}{2}$	420	SKHG 112/32
	*40	38	G1 $\frac{1}{2}$	420	SKHG 112
	50	38	G2	420	SKHG 2/38
*50	48	G2	420	SKHG 2	

*Indicates stock sizes

Ph: (07) 3279 2627 Email: Sales@flanges-au.com Fax: (07) 3279 2630

11/45 Jijaws Street Sumner Park Qld 4074 PO Box 525 Sumner Park Q 4074



flanges australia

BALL VALVES Block-type

BALL VALVES Block-type BKH

Series 040

DN 4 TO DN 25

Body, connecting parts, ball and stem steel.

Fields of application:

hydraulics, particularly in construction industry and agricultural machinery, water engineering, mining industry, paint industries.

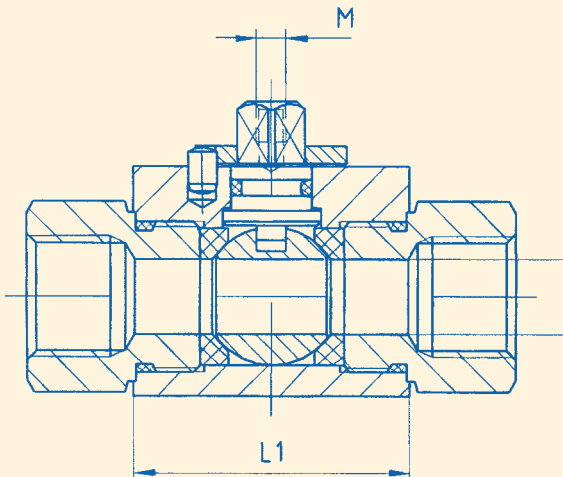
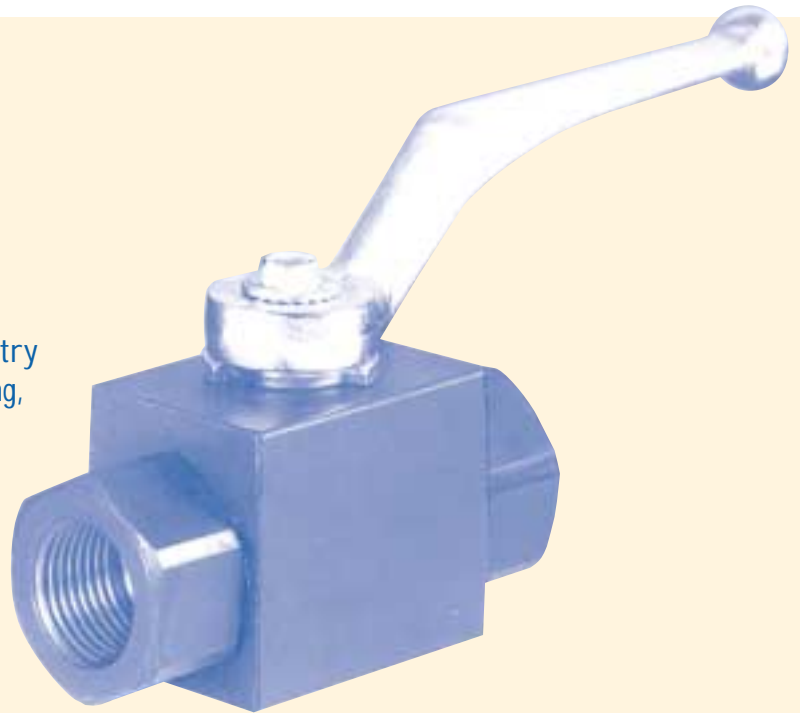

Body:	Steel
Ball:	Steel nickel pl.
Stem:	Steel zinc pl.
Ball sealing:	Polyamid/POM (DN 16)
Stem sealing:	NBR

Connection	DN mm	LW mm	D	PN BAR	Part Number
BSP female thread DIN/ISO 228	*4	5	G $\frac{1}{8}$	500	BKR 04
	*6	6	G $\frac{1}{4}$	500	BKR 06
	8	8	G $\frac{3}{8}$	500	BKR 10/08
	*10	10	G $\frac{3}{8}$	500	BKR 10
	*13	13	G $\frac{1}{2}$	500	BKR 13
	16	15	G $\frac{1}{2}$	500	BKR 13/15
	*20	20	G $\frac{3}{4}$	400	BKR 20
*Indicates stock sizes	*25	24	G1	350	BKR 25
	*32	24	G1 $\frac{1}{4}$	350	BKR 32

Ph: (07) 3279 2627 Email: Sales@flanges-au.com Fax: (07) 3279 2630

11/45 Jijaws Street Sumner Park Qld 4074 PO Box 525 Sumner Park Q 4074



flanges australia

Three-way BALL VALVES

Three-way BALL VALVES BK3/SK3

L-or T bore

Series 100

DN 4 TO DN 50

Body, ball and stem steel, from DN 20 on body forged steel.

Fields of application:

hydraulics, agricultural and mobile hydraulics stainless steel versions are used in chemical and petrochemical industry, painting industry

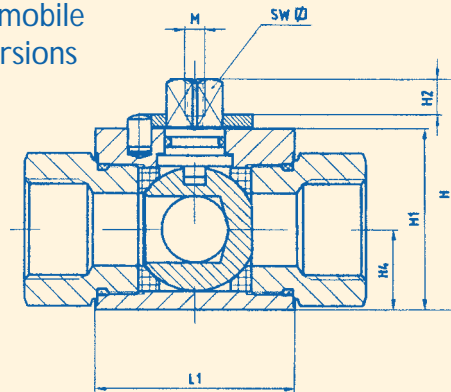

DN mm	BSP	PN bar	L1 mm	B mm	H mm	H1 mm	H2 mm	H4 mm	M mm	SW mm	Part Number
4	1/8	400	36	26	43,5	32	8	13	M5	9	3 BKR 04
6	1/4	400	36	26	43,5	32	8	13	M5	9	3 BKR 06
8	3/8	400	36	26	43,5	32	8	13	M5	9	3 BKR 10/8
10	3/8	400	43	32	49	38	8	16,5	M5	9	3 BKR 10
13	1/2	350	48	35	51	40	8	17,5	M5	9	3 BKR 13
16	1/2	350	48	38	62	46	12	19	M6	12	3 BKR 16
20	3/4	350	61	49	73	57	12	24,5	M6	14	3 BKR 20
25	1	350	65	60	76	60	12	26,5	M6	14	3 BKR 25
32	1 1/4	350	80	76	104	84	13,5	38	M8	17	3 BKR 32
40	1 1/2	350	85	83	111	92	13,5	41,5	M8	17	3 BKR 40
50	2	350	100	100	130	111	13,5	50	M8	19	3 BKR 50

L-bore 0° - 90°
Order Code: LK

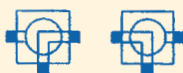

T-bore 0° - 90°
Order Code: TK



Suffix LK = L Port
TK = T Port

In middle position (90°) only pressurising of third port possible.

The sealing function of **BK3/SK3-standard** valves is only given when the pressure standing on the closed port is zero or if the pressure between connected ports is higher than the pressure on the closed port.

No shut-off position for the third port possible!

To apply **pressure from all ports** (PN1=PN2), a special variant is required. Add **A** to the order code.

Ph: (07) 3279 2627 Email: Sales@flanges-au.com Fax: (07) 3279 2630

11/45 Jijaws Street Sumner Park Qld 4074 PO Box 525 Sumner Park Q 4074



flanges australia

Low Pressure BALL VALVES

BSPF Female	BSP mm	Length mm	PN Bar	Part Number
G 1/4	10	48	50	BKR 06 ND
G 3/8	10	48	50	BKR 10 ND
G 1/2	15	51	50	BKR 13 ND
G 3/4	20	57	40	BKR 20 ND
G 1	25	70	40	BKR 25 ND
G 1 1/4	32	80	30	BKR 32 ND
G 1 1/2	40	93	30	BKR 40 ND
G 2	50	112	25	BKR 50 ND
G 2 1/2	65	134	18	BKR 65 ND
G 3	80	156	16	BKR 75 ND
G 4	100	191	14	BKR100 ND



MATERIAL:
 Housing – Nickel/Brass
 Ball – Chrome/Brass
 Sealing – Teflon
 Handle – Aluminium
 Temperature – -15c to +150c



THREE WAY BALL VALVE - Low Pressure

T-Type NDT
 L-Type NDL

BSPF Female	Bore mm	Length mm	Width mm	PN Bar	Part Number
G 1/4	10	77	58	25	3 BKR 06 NDT
G 3/8	12	77	58	25	3 BKR 10 NDT
G 1/2	14	77	58	25	3 BKR 13 NDT
G 3/4	18	92	70	25	3 BKR 20 NDT
G 1	23	104	80	25	3 BKR 25 NDT

BSPF Female	Bore mm	Length mm	Width mm	PN Bar	Part Number
G 1/4	10	77	58	25	3 BKR 06 NDL
G 3/8	12	77	58	25	3 BKR 10 NDL
G 1/2	14	77	58	25	3 BKR 13 NDL
G 3/4	18	92	70	25	3 BKR 20 NDL
G 1	23	104	80	25	3 BKR 25 NDL

MATERIAL:
 Housing – Nickel Plated Brass
 Ball – Hard Chrome Brass
 Sealing – Teflon
 Handle – Aluminium
 Temperature – -15c to +150c

Ph: (07) 3279 2627 Email: Sales@flanges-au.com Fax: (07) 3279 2630

11/45 Jijaws Street Sumner Park Qld 4074 PO Box 525 Sumner Park Q 4074



flanges australia

Quick Release COUPLINGS

APPLICATIONS:

High pressure, spring loaded quick connect suitable for industrial/agricultural applications.

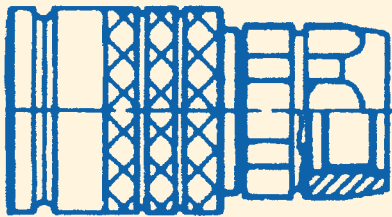

PUSH/PULL
Quick Release Coupling
Female with BSPP thread
ISO 'B' STD

BSPP	Max Bar	Part Number
G 1/8	450	SKM 04 IR 1
G 1/4	450	SKM 06 IR 1
G 3/8	450	SKM 10 IR 2
G 3/8	350	SKM 10 IR 3
G 1/2	350	SKM 13 IR 3
G 3/4	250	SKM 20 IR 5
G 1	250	SKM 25 IR 5

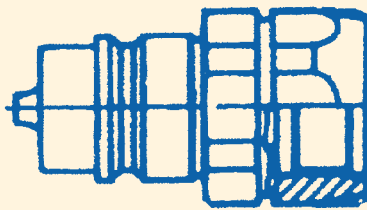

PUSH/PULL
Quick Release Coupling
Male with BSPP thread
ISO 'B' STD

BSPP	Max Bar	Part Number
G 1/8	450	SKS 04 IR 1
G 1/4	450	SKS 06 IR 1
G 3/8	450	SKS 10 IR 2
G 3/8	350	SKS 10 IR 3
G 1/2	350	SKS 13 IR 3
G 3/4	250	SKS 20 IR 5
G 1	250	SKS 25 IR 5



flanges australia

Quick Release Screw COUPLINGS

APPLICATIONS:

Heavy duty construction, high pressure applications, suitable for high pulsation hydraulic circuits such as hydraulic hammers.

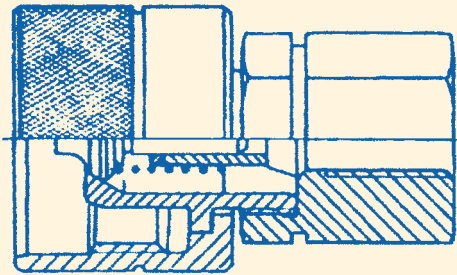

SCREW TYPE (Female)
Quick Coupler
BSPF (F) thread

BSPF	Max Bar	Part Number
G 1/4	450	SKL 06 IR 1
G 3/8	450	SKL 10 IR 2
G 1/2	450	SKL 10 IR 3
G 3/4	450	SKL 13 IR 3
G 1	400	SKL 20 IR 4
G 1 1/4	300	SKL 20 IR 5
G 2	300	SKL 25 IR 5

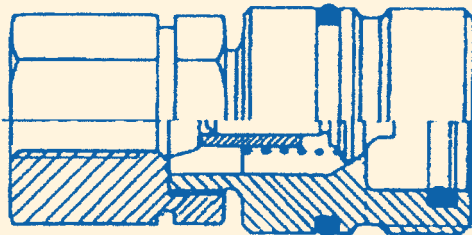

SCREW TYPE (Male)
Quick Coupler
BSPF (F) thread

BSPF	Max Bar	Part Number
G 1/4	450	SKF 06 IR 1
G 3/8	450	SKF 10 IR 2
G 1/2	450	SKF 10 IR 3
G 3/4	450	SKF 13 IR 3
G 1	400	SKF 20 IR 4
G 1 1/4	300	SKF 20 IR 5
G 2	300	SKF 25 IR 5